

1064 nm Single Mode Spectrum Stabilized Laser

Model # I1064S50100B

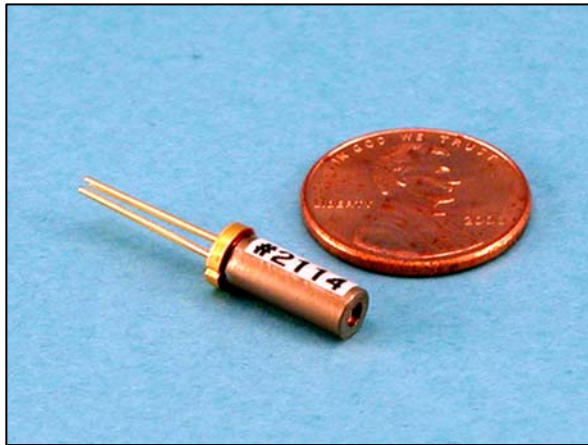

Features:

- High Power Single Mode Output (>100 mW)
- Ultra-Narrow Spectral Bandwidth (< 100 MHz)
- Stabilized Output Spectrum (< 0.007 nm/°C)
- Circularized & Collimated Output Beam
- Integral Laser Line Filter
- Integral Thermistor
- Integral ESD Protection

Innovative Photonic Solution's proprietary Single-Mode Spectrum Stabilized Laser features high output power with ultra-narrow spectral bandwidth and a diffraction limited output beam. Designed to replace expensive DFB, DBR, fiber, and external cavity lasers, the Single-Mode Spectrum Stabilized Laser offers superior wavelength stability over time, temperature (0.007 nm/°C), and vibration, and is manufactured to meet the most demanding wavelength requirements.

The I1064S50100B comes standard with a circularized and collimated output beam, integral laser line filter, internal thermistor and ESD protection. Lasing wavelength can be accurately specified and repeatedly manufactured to within 0.1 nm. The laser is ideal for laser seeding, high resolution Raman spectroscopy, confocal microscopy, metrology and interferometry applications.

Typical Spectral Plot:

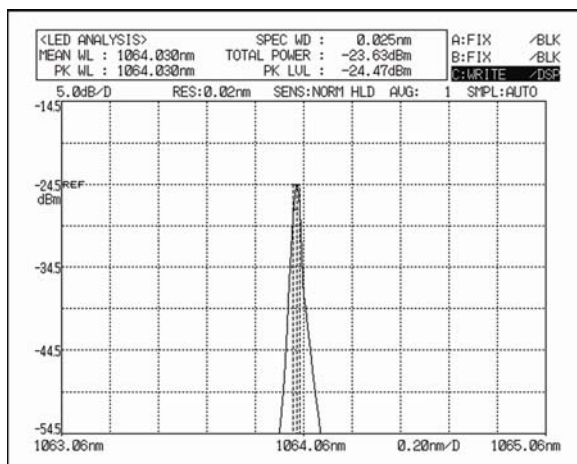

1064 nm SS Laser Spectrum @ 25 deg C

Ultra-Stable Performance
With Spectral Linewidth
As Low As 150 KHz

Product Specifications:

Parameter	Unit	Min	Typ	Max	Notes
Optical output power	mW	100	120		Circularized & collimated output beam with <0.7 mm dia (1.5:1 aspect ratio) and <2.5 mrad divergence
Output power stability	%		± 1		
Peak wavelength	nm	1064	1064.4	1065	
3 dB bandwidth (FWHM)	nm		<100 MHz	0.03	
Wavelength Stability Range	Deg C	15		45	Minimum case temperature range where laser remains locked and no side bands are existant
Polarization Extinction Ratio	dB	17	20		

Mechanical Specifications:

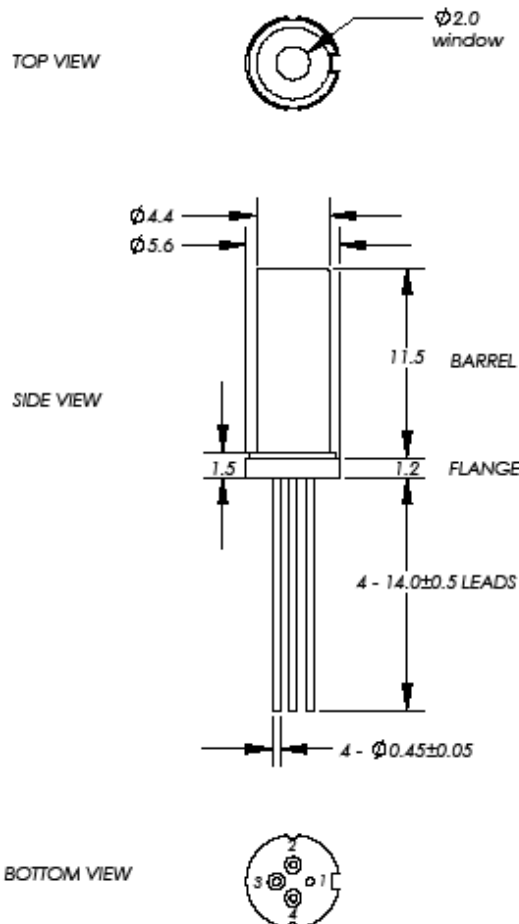

PRODUCT SPECIFICATION

Revision: 2/2/2010

(1) Features

- Single-mode wavelength stabilized laser diode
- collimated circular optical beam
- integrated Raman laser line filter
- integrated ESD protection

(2) Electrical Pin-out (see bottom view)

- pin 1: LD Anode (+); case ground; (optional: PD Cathode)
- pin 2: LD Cathode (-)
- pin 3: Thermistor; (optional: PD Anode)
- pin 4: Thermistor - 10 kOhm @ 25 deg. C

(3) Optical Specifications

Single-mode wavelength stabilized laser diode

Optical output power: 200 mW typ

Wavelength: 1064 nm +/- 0.5 nm (measured in air)

Side-mode suppression: 45 dB MIN

Long-wavelength suppression: 100 dB MIN

Linewidth: 0.03 nm MAX; Less than 100 MHz TYP

Optical beam diameter: 0.5 - 1.0 mm

Beam aspect ratio: 1:1.5 MAX

Beam divergence: 2 mrad MAX

Polarization: 20 dB MIN; in plane with two triangular notches

(4) Operating conditions

Operating current: 400 mA MAX

Threshold current: 40 mA TYP

Operating temperature range: 15-45 deg C

Preferred operating temperature: 30-35 deg C

Laser stays locked over entire operating range

(5) Mechanical Specifications

- Device is compatible with industry-standard TO-56 mounts
- Device needs to be mounted and heat-sunk using its flange
- Barrel is not designed for heat-sinking or mechanical support

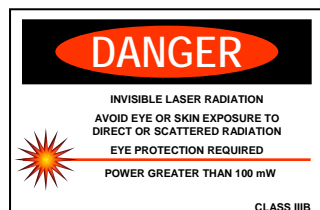

OEM Laser Product

This laser module is designed for use as a component (or replacement) part and is thereby exempt from 21 CFR 1040.10 and 1040.11 provisions.