

High Power Galvanometer Welding System

FEATURES

- Adopt high precision and high speed digital grating galvanometer,welding speed up to 3000mm/s
- Adopt closed-loop control system to monitor the position and status of the galvanometer at the real time
- Adopt high level system safety mechanism,turn off laser within 10ms
- Support both water cooling and air cooling system .With high-end and dignified cabinet
- With a variety of swing functions :wave-shaped trajectory ,spiral trajectory ,8 trajectory and ∞ trajectory.
- Independent design PC software, It sets energy waveform ,swing function ,welding parameters ,with debugging mode and automatic welding mode simultaneously .

TECHNICAL PARAMETERS

	Thunder 6000	Thunder 3000
Maximum Laser Power (kw)	6000	3000
Laser Wavelength (nm)	1070±10	
F-theta Lens Effective Focal Length (mm)	460	
Welding Range (mm)	220×220	
Operating Height (mm)	565	
Collimator Effective Focal Length (mm)	150	
Fiber Connection Method	QBH	
Clear Aperture (mm)	30	
Maximum Welding speed (mm/s)	3000	
Operating Temperature (°C)	25±10	
Weight (kg)	20	

Note:①Different focus length collimator available

②Test with F=460mm F-theta lens

SOFTWARE INTERFACE

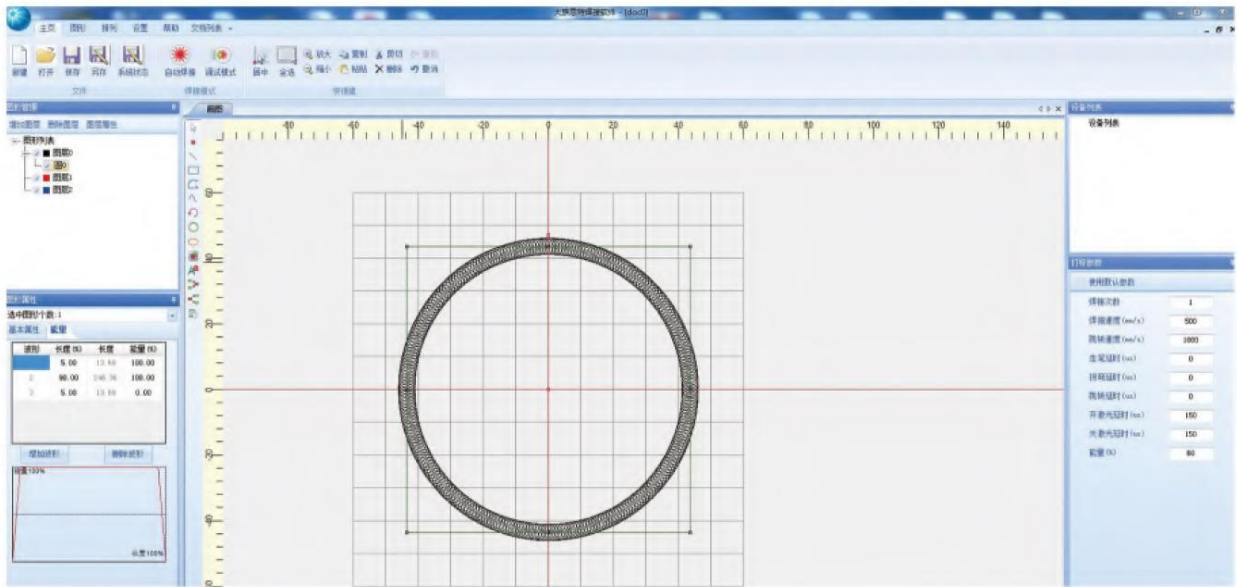

TECHNICAL DRAWING

高功率焊接振镜外形安装尺寸
Installation dimension of high power welding galvanometer

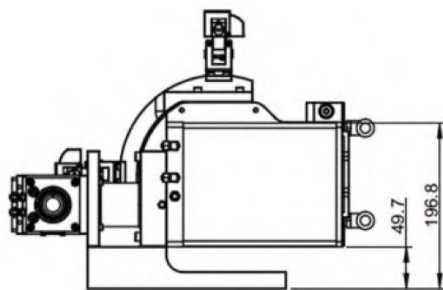
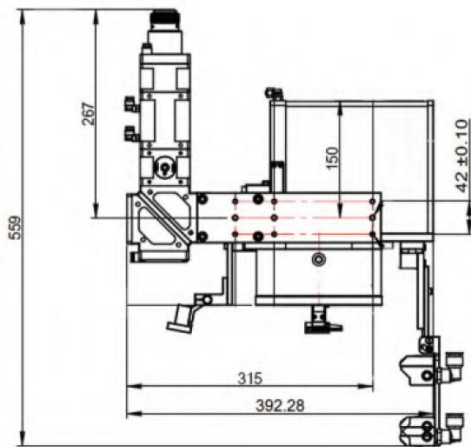

机柜外形尺寸图
Technical drawing of cabinet

